

Casino



Score Board



Airport

SPECIFICATIONS

Model	MW7719-FI	MW7726-FI	MW7729-FI	MW7739-FI
Pixel Pitch	1.9mm	2.6mm	2.9mm	3.9mm
LED Type	SMD	SMD	SMD	SMD
Module Size(mm)	250*250	250*250	250*250	250*250
Module Resolution	128*128	96*96	84*84	64*64
Cabinet Size(mm)	500*500*83	500*500*83	500*500*83	500*500*83
Cabinet Resolution	256*256	192*192	168*168	128*128
Cabinet Weight(kg/pcs)	8	8	8	8
Brightness(nits)	600-700	600-700	600-700	600-700
Cabinet Material	Die-cast aluminum	Die-cast aluminum	Die-cast aluminum	Die-cast aluminum
Viewing Angle	160°/140°	160°/140°	160°/140°	160°/140°
Contrast	5000:1	5000:1	5000:1	5000:1
Refresh Rate	3840Hz	3840Hz	3840Hz	3840Hz
Gray Scale Processing	14bit	14bit	14bit	14bit
Input Voltage	AC 100 to 240V, 50/60Hz	AC 100 to 240V, 50/60Hz	AC 100 to 240V, 50/60Hz	AC 100 to 240V, 50/60Hz
Input Power(Avg)	163	164	164	166
Input Power(Max)	489	490	490	500
Maintenance Mode	Front/rear maintenance	Front/rear maintenance	Front/rear maintenance	Front/rear maintenance
Ingress Protection	Front/rear IP30/IP30	Front/rear IP30/IP30	Front/rear IP30/IP30	Front/rear IP30/IP30



www.unvdisplay.com

Sales: overseasbusiness@uniview.com

Technical Support: globalsupport@uniview.com

2023.05

Disclaimer: All rights reserved, including final interpretation and content amendm



FL Series Indoor Fixed LED

INTRODUCTION

Product Features

- Available Pixel Pitch 1.9|2.6|2.9|3.9mm
- Brightness 700nits
- High-precision Die-cast Aluminum Panel
- Panel Dimensions 500mm*500mm*83mm
- GOB Optional

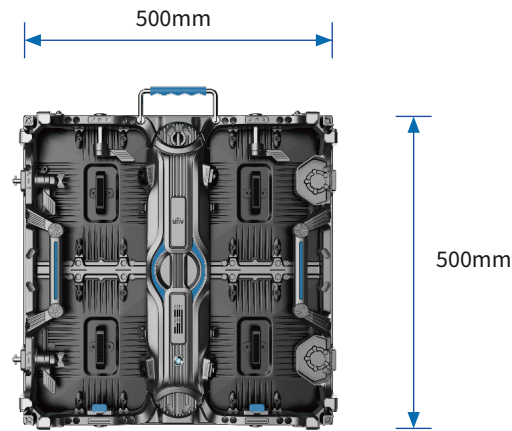

3840

High Refresh Rate

8kg

Weight Only 8kg



One Man Installation



Front/Rear Maintenance

High-precision Panel Design

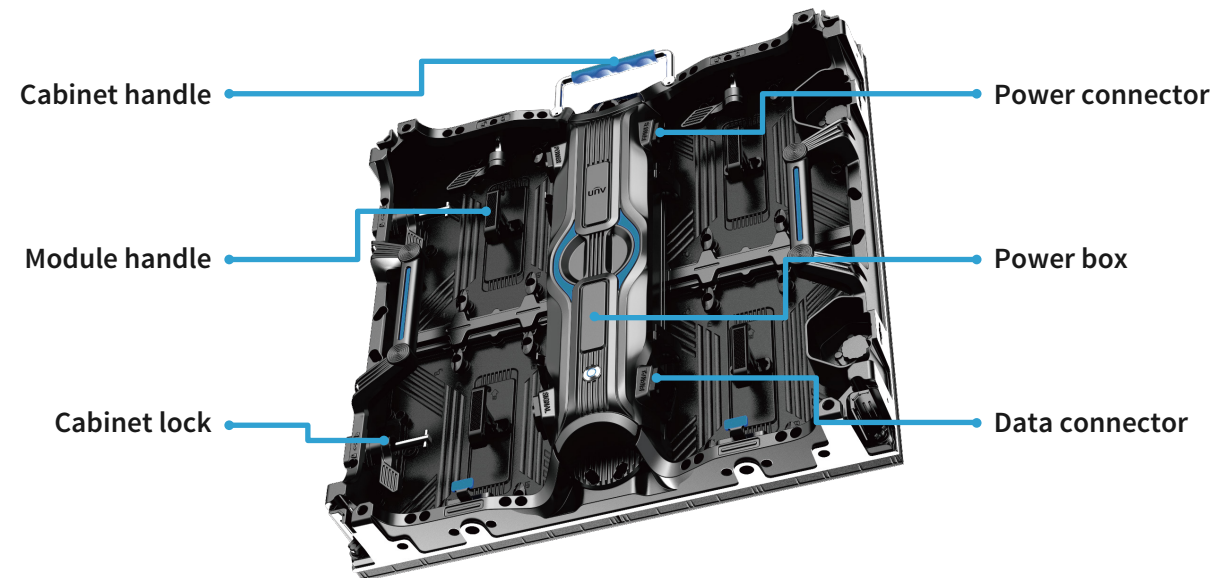

PERFECT VISUAL EXPERIENCE

Delicate and Smooth Video

3840Hz high refresh rate eliminates streaks on the screen, enhances the clarity and contrast of the image, making the video picture delicate and smooth.

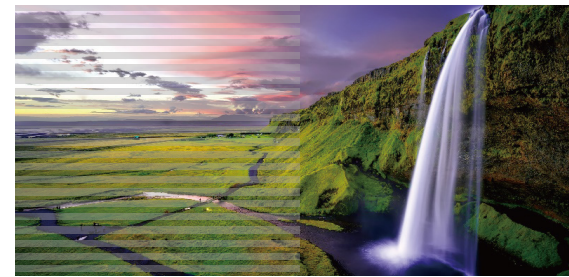

Vivid Color Displaying

HDR processing technology enhances image quality and vivid color displaying.

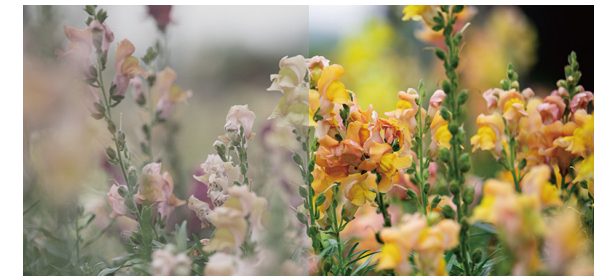

Higher Visual Uniformity

Pixel-by-pixel calibration technology eliminates the difference in brightness and chromaticity within and between panels, improving the uniformity of display.



Clearly Visible under Low Brightness

High grayscale level under low brightness ensures the details of the image are clearly visible.

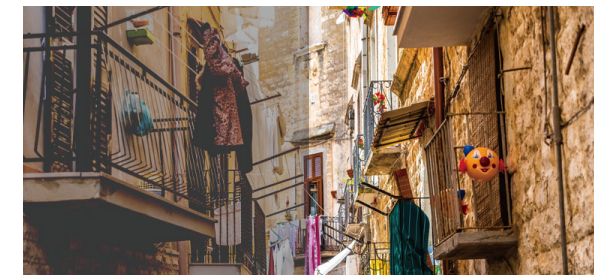

APPLICATION SCENARIOS

